

MXM5071
MXM6071



ADVANCED SERIES MONOCHROME DOCUMENT SYSTEMS



"Most Reliable Monochrome Copier MFP Brand 2018-2021"



"2019 Copier MFP Line of the Year"
"New to the Line"

SHARP[®]

Be Original.

The New Sharp Monochrome Advanced Series document systems deliver cutting-edge integration and powerful productivity.

DESIGNED FOR THE TECHNOLOGY-DRIVEN WORKPLACE

advanced

The Sharp MXM5071 and MXM6071 **ADVANCED SERIES MONOCHROME DOCUMENT SYSTEMS** are built using the latest technology available to deliver the performance, features and reliability needed in today's busy workplace environments. These new MFPs are also easy to use and offer enhanced productivity, all to provide customers with a seamless, intuitive experience, and the confidence in knowing their jobs will come out right the first time, every time. The new Monochrome Advanced Series also offers leading-edge security features to help businesses protect their data and personal information.

Key Features

- **EASE-OF-USE** – Award-winning touchscreen display offers a user-friendly graphical interface with simplified Easy Modes, integrated user guides and quick access to network services.
- **PRODUCTIVE FEATURES** – Standard full multifunction capability out-of-box, including copying, network printing and colour network scanning. New Adobe Embedded Print Engine technology direct prints PDF files from a variety of sources with greater performance and rendering accuracy.
- **WORKPLACE FRIENDLY** – Integrates seamlessly with today's complex network environments, and supports popular cloud services and mobile technologies. Sharp's new Application Portal enables administrators to easily add new apps or update existing apps right from the MFP.

The new MXM5071 and MXM6071 **MONOCHROME ADVANCED SERIES** offers businesses powerful multitasking features, enabling them to quickly execute the ever-changing workflow tasks of today's busy office environments.

That's the **SHARP DIFFERENCE**.



 POWERED BY
Adobe Embedded Print Engine

POWERFUL PERFORMANCE, STRONG PRODUCTIVITY



An advanced design plus multifunctional capability allow you to meet tomorrow's business needs today.

- Standard 150-sheet **duplexing single-pass document feeder** scans documents at speeds up-to 220 images per minute (ipm).
- **Flexible paper handling** supports media up-to 110 lb. cover (300 gsm) and feeds up-to 12" x 18" through the paper trays, allowing users to print on a wide variety of media.
- Network-ready **PCL® 6** and **Adobe® PostScript® 3™** printing systems ensure your documents print with the clarity and formatting you expect.
- Easily **convert documents** to popular Microsoft® file formats, as well as a variety of PDF formats, with standard OCR (optical character recognition) capabilities.
- Award-winning 10.1" (diagonal) **customizable touchscreen display** with a clean design enables easy access to features and functions when setting up jobs.

EASY-TO-USE

PRODUCTIVE FEATURES

WORKPLACE FRIENDLY



"BLI PaceSetter Award in Ease of Use"
Enterprise Devices 2018-2019



- **Built-in walk-up motion sensor** automatically detects approaching users and immediately wakes the machine, making it ready for use within seconds.
- Standard **wireless networking** feature can connect directly to your network or to mobile devices for convenient scanning and printing with the **Sharpdesk® Mobile App**.
- Access popular cloud services, such as Microsoft OneDrive™ for Business, SharePoint® Online, Google Drive™, Dropbox and more with Sharp's **Cloud Connect** feature.
- **Multi-layered, leading-edge security features** provide enhanced protection while an End-of-Lease feature can erase all data and personal information at time of trade-in.



Built-in retractable keyboard simplifies email address and subject line entries as well as repetitive scanning tasks and user authentication.



ENHANCED FUNCTIONALITY – INTUITIVE DESIGN



Easy Copy Screen offers the most commonly used settings.



MXM6071 shown in both a compact configuration with inner finisher and full configuration with saddle-stitch finisher and large capacity cassette.

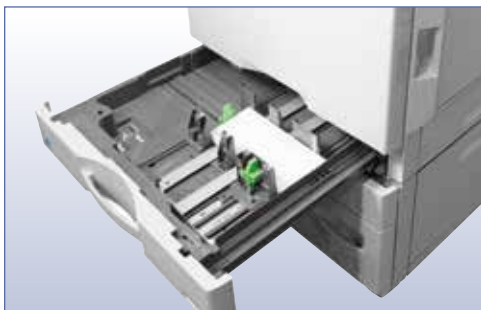

Feeds up-to 50 envelopes from the standard paper tray.

From paper handling to networking, the MXM5071 and MXM6071 Monochrome Advanced Series will exceed your expectations.

Simple and Intuitive Operation

From the most basic of copy functions, to the most complex scan jobs, the Monochrome Advanced Series will perform them with ease and efficiency. Use one of the **Easy Modes** for fast, simple operation, with basic functions displayed in **large, clearly-labeled tiles** and keys. Easy Modes are available for the standard copy and scan functions, as well as for the optional fax expansion kit. And for more advanced features, just touch the “Detail” button—it’s that easy.

The Productivity You Need with the Performance You Want

When it’s time to get the job done, the Advanced Series Monochrome Document Systems are outstanding performers. Quickly scan documents at speeds up-to **220 ipm**. Then use the **manual stapling feature** on select finishers to restaple your originals. **Multiple finishing options** give you the output you require, be it stacked, stapled, or saddle-stitched. There’s even an available built-in **stapleless finishing** feature, which can bind up-to five sheets of paper by adding a crimp to the corner of the set, saving regular staples for larger sets. These models also feed up-to 50 envelopes from the standard paper tray.*



**See specifications for a list of supported envelopes.*

HIGH IMPACT VERSATILITY AND SCALABILITY

The MXM5071 and MXM6071 Advanced Series Monochrome Document Systems provide high-performance functionality that easily adapts to your business needs.

innovative features

Duplexing Single Pass Feeder (DSPF)

Standard 150-sheet dual head document feeder scans both sides of a document in a single pass, and a built-in indicator light flashes to remind you to take your originals.

Convenient Wireless Networking

Scanning and printing from mobile devices is made quick and easy with the available Sharpdesk Mobile App.

Easy-to-Use Smart Touchscreen

Award-winning, tablet-style menu provides quick access to features and functions.

High Quality Printing

1,200 x 1,200 dpi resolution produces razor-sharp documents. Adobe PostScript 3 drivers offer extensive job control.

Built-in Retractable Keyboard

Full-size QWERTY keyboard enables easy data entry.

In-line Stapling

Produce professional-looking corner-staple or edge-staple documents up-to 65 pages.

Manual Stapler

Manual stapling feature makes it easy to re-staple originals after scanning.

Saddle Stitch Finishers

Make high quality booklets up-to 80 pages.

Advanced Finishing

Sharp gives you a choice of five high-performance finishers to give your documents a professional look. Choose from a compact inner finisher to a high-capacity, floor-standing saddle-stitch finisher.

Flexible Paper Handling

Paper drawers feed up-to 12" x 18" and support media up-to 300 gsm. Also feeds up-to 50 envelopes through the standard paper tray.* A variety of paper tray options are available, including a large capacity cassette and split tandem paper drawers.

Walk-up Motion Sensor

Detects walk-up users and wakes the machine from sleep mode, making it ready for use within seconds.

100-sheet Bypass Tray

Manual bypass tray feeds envelopes, OHP film, glossy paper, as well as paper up-to 300 gsm.

Multi-layered Security Features

Leading-edge security features provide enhanced protection of data and personal information and helps protect against network intrusions.

Large Capacity Cassette

Large capacity cassette option adds an additional 3,000 sheets of paper for a total on-line capacity of up-to 6,300 sheets.



* See specifications for a list of supported envelopes.

ENHANCED COLLABORATION FOR STREAMLINED WORKFLOWS



Access popular cloud applications, distribute files and print documents more easily.



Scan and convert documents to popular file types seamlessly with Sharp's built-in OCR function.

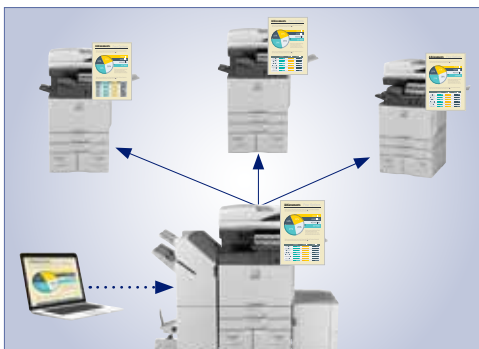

Standard Serverless Print Release enables users to securely print a job and release it from up-to six supported models on the same network.

Powerful document workflow solutions help you work more efficiently.

Distribute, Access and Print Your Documents with Ease

Sharp makes it easy to go beyond traditional network scanning with standard **Email Connect** and **Cloud Connect** features. With **Email Connect**, scan to email is seamlessly integrated with Microsoft Exchange/Office 365[®] and Gmail[™] user accounts, making it easy to identify the sender of scanned files. With Cloud Connect, users can easily scan-to and print-from **Microsoft OneDrive for Business, SharePoint Online, Google Drive, Box and Dropbox**. And with Sharp's new Application Portal, administrators can **easily add new apps** and update existing apps right from the MFP touchscreen panel.



Scan and Print Files Easily from Mobile Devices

The Advanced Series Monochrome Document Systems also make it easy to scan and print files from tablets and smartphones using **Sharpdesk Mobile**, a free downloadable app available for most mobile devices.* These new models also support popular mobile technologies such as **Apple[®] Airprint[®], Android[™] print framework and Google Cloud Print[™]**. With standard **wireless networking**, users can also print directly to the MFP from mobile devices without interfering with the corporate network!

Simplify Managing Different File Types with Intelligent Image Processing

With standard OCR capabilities, users can easily scan and convert documents to popular file formats including Microsoft Word, PowerPoint and Excel, as well as Searchable PDF, Encrypted PDF and others. You can even directly print these same file types from thumb drives, cloud applications and mobile devices. This function is enabled via Qualcomm DirectOffice technology. These new models also support the new **Adobe Embedded Print Engine**, which direct prints PDF files from a variety of sources with greater performance and rendering accuracy.

Flexible Printing Solutions Help Maximize Productivity

Standard PCL 6 and Adobe PostScript 3 printing systems to help you speed through all of your output needs. Sharp's **Serverless Print Release** feature enables users to securely print a job and release it from up-to six supported models on your network.* And with **Google Cloud Print**, you can send print jobs from Chromebook[™] notebook computers, PCs and more from virtually anywhere.

Simplify Complex Business Workflows with Sharp OSA[®] Technology

Sharp OSA technology can help your business leverage the power of your network applications, back-end systems and cloud services. Easily automate complex processes and help eliminate redundant tasks. Talk to your authorized Sharp dealer to see how they can help you implement a streamlined workflow solution.



*Go to www.sharp.ca for a list of supported equipment and operating systems.

TAKING CARE OF BUSINESS SAFELY AND SECURELY

Manage your device, help safeguard your data, help protect your business.

To help protect employees' privacy and intellectual property, the new Monochrome Advanced Series is armed with leading-edge, **multi-layered security features**, including **Firmware Attack Prevention and Self Recovery**, which can help identify a malicious intrusion and restore the machine firmware to its original state. The new **Application Whitelisting** feature detects access attempts to the machine file system and denies access if the source data is not on the whitelist. **Authority Groups** help manage and restrict copying, printing and scanning features to safeguard data and control costs. Administrators can also apply **Active Directory® Group Policy** to the device, which offers centralized configuration and control. **Confidential Printing** helps ensure sensitive documents are kept safe by requiring users to enter a PIN code to print them. These models also support Active Directory user authentication and secure **Single Sign-On**. **Integrated ID card authentication** is also available.* When you are ready to trade the machine in, a convenient **End-of-Lease** feature can erase all data and personal information, as well as print a confirmation report.



These scalable security offerings aim to **protect your intellectual property**, preserve confidential information and help your business meet regulatory requirements such as the Personal Information Protection and Electronic Documents Act (PIPEDA).

**Some features require optional equipment and/or software.*



With **Sharp Remote Device Manager (SRDM)**, administrators can take control of system features and simplify installation and management. SRDM makes it easy to view service logs, click counts, history reports and more. Event-driven service alerts help monitor the device and maximize uptime. The centrally managed **security dashboard** monitors security settings and can automatically reset the security policy if changed locally at the machine. Also, **Centralized Admin Password Management** and **Centralized Power Management** make it easy to deploy changes when needed. The **Remote Front Panel** feature enables administrators to control the machine's LCD panel from a PC to troubleshoot issues and train operators. Sharp also offers both **built-in** and additional **auditing hardware and software to control, access and track usage** of each device on the network.*

And with **YourSharp™**, you get a dedicated training website customized to your Advanced Series model to help you understand all of the features.

your SHARP experience



ENVIRONMENTAL COMMITMENT



An Environmentally Responsible Approach to Product Design

Sharp is committed to environmental sustainability and corporate responsibility including planning, design, manufacturing, distribution and product end-of-life management. The Monochrome Advanced Series adhere to Sharp's Green Products Guidelines in pursuit of these commitments. These guidelines include designing products that consume less power, using recycled materials, reducing the amount of material used in products and packaging, and labeling the type of materials used. Sharp also aims to design products that are upgradable, easy to repair and easy to take apart for recycling.

The MXM5071 and MXM6071 document systems are **ENERGY STAR®** qualified and **RoHS** compliant to restrict the use of hazardous substances. These products also have low **TEC** (Typical Electricity Consumption) values. Sharp MFPs are **EPEAT®** registered.



Toner Recycling Program

As part of our commitment to helping preserve the environment, Sharp offers our customers zero-waste-to-landfill recycling for Sharp consumables, including cartridges, bottles, toner collection containers and drum units. Sharp encourages customers to recycle their used Sharp toner cartridges in bulk by providing a pre-paid Recycling Kit for their return to our facility. Please visit <http://www.sharp.ca/support-toner.aspx> to learn more.

Environmental Leadership

As a testament to our commitment to the environment, Sharp is a multi-year winner of the **ENERGY STAR®** annual **Excellence in Energy Proficiency Product Design**. Sharp was also a previous recipient of the **Excellence in Partnership Green Contractor Award** and the **Evergreen Award** from the General Services Administration (GSA) and the Coalition for Government Procurement. These awards recognize environmentally responsible businesses and their efforts on recycling, waste reduction and affirmative procurement practices.

For more information about Sharp's environmental leadership including details about energy efficient products, electronics or toner cartridge recycling, please visit <http://www.sharp.ca/about-us-environmental-policy.aspx> to learn more.

MXM5071/MXM6071 SPECIFICATIONS

Main Specifications

MXM5071/ MXM6071	Base models include: multitasking controller, 150-sheet DSPF, PCL 6 and Adobe PostScript® 3™ printing systems, network scanning, auto duplexing, 1 x 550-sheet paper drawer, 100-sheet bypass tray.
Type	Monochrome multi-function digital document system
Display	10.1" (diagonally measured) colour dot matrix high-resolution touch panel tilting display, 1.024 x 600 dots (W-SVGA)
Functions	Copy, print, network print, network scan, document filing and fax ¹
Copy System	Dry electrostatic transfer/Dual component developer/Magnetic brush development/OPC drums/Belt fusing/white LED exposure
Originals	Sheets and bound documents
Max. Original Size	11" x 17"
Output Size	Min. 5.5" x 8.5", Max. 12" x 18"
Copy Speed	50/60 ppm (8.5" x 11")
Multiple Copy	Max. 9,999 copies
First Copy Time (In Seconds)²	MXM5071 MXM6071
	Platen Glass 3.7 3.5
	DSPF 6.6 6.3
Warm Up Time	MXM5071: 29 seconds (from main power switch on), 16 seconds (from [Power] button on) MXM6071: 31 seconds (from main power switch on), 18 seconds (from [Power] button on)
Magnification	25% to 400% in 1% increments (with DSPF 25%-200%)
Original Feed	150-sheet DSPF with original size detection
Scan Speed	Copy: Up to 220 ipm (Mono) Scan: Up to 220 ipm (Mono/Colour)
Original Sizes	5.5" x 8.5", 8.5" x 11", 8.5" x 11" R, 8.5" x 14", 11" x 17"
Paper Capacity	Standard: 650 Sheets, Maximum: 6,300 Sheets
Paper Feed System	Standard: (1) paper drawer 550 sheets (letter/legal/ledger/stmt. size) or up to 50 envelopes (max. height: 25 mm), 100-sheet (or 20 envelope) bypass tray. Optional: Single, double, or triple paper drawer(s) (550, 1,100, or 1,650 sheets), split tandem paper drawers 2,100 sheets (letter) + (1) 550-sheet paper drawer (letter/legal/ledger/statement size).
Paper Weights and Types	Paper drawers: 18 lb. bond to 110 lb. cover. Drawer 1: 20-24 lb. bond or Monarch/Com-9 envelopes. Split Tandem Drawers: 18 lb. bond to 28 lb. bond or plain, pre-printed, recycled, pre-punched, letterhead and colour paper. Bypass tray: 16-28 lb. bond (plain paper), 13-16 lb. bond (thin paper), 28 lb. bond-110 lb. cover (heavy paper), tab paper (letter) and Monarch/Com-10 envelopes. Also label, gloss, pre-printed, recycled, pre-punched, letterhead and colour paper or OHP film.
Duplexing	Standard automatic duplex copying and printing
CPU	Up to 1.4 GHz multi-processor design
Interface	RJ-45 Ethernet (10/100/1000 Base-T), USB 2.0: 2 host ports (front and rear), wireless 802.11 b/g/n
Memory	Standard 5 GB copy/print (shared)
Hard Disk Drive	500 GB
Copy Resolution	Scan: Up to 600 x 600 dpi Output: Up to 1200 x 1200 dpi
Copy Modes	Monochrome/Greyscale
Exposure Control	Automatic, Text, Text/Photo, Text/Printed-Photo, Printed-Photo, Photo, Map, Pale-Colour Document.
Modes	Settings: Auto or 9 step manual
HalfTone	256 gradations/2 levels (monochrome)
Copy Features	Scan-Once Print-Many, electronic sorting, offset-stacking, Auto Paper Selection (APS), Auto Magnification Selection (AMS), Auto Tray Switching (ATS), black-white reversal, blank page skip, book copy, book divide, card shot, centre erase, centring, cover pages, dual page copy, edge erase, image edit, image preview, insert pages, job build, job programs, margin shift, mirror image, mixed size original, multi-page enlargement, original count, pamphlet style, proof copy, repeat layout, reserve copy, rotated copy, stamp, stamp custom image, suppress background, tab copy, tab-paper insertion, tandem copy, toner save mode, transparency inserts, watermark, 2-in-1 / 4-in-1 / 8-in-1 multi shot
Account Control	Up to 1,000 users. Supports user-number authentication via local, LDAP and Active Directory for copy, print, scan and document management

Main Specifications (continued)

Output Tray Capacity	Centre Exit Tray (Main): 250 sheets (face down) Job Separator (Upper Tray): 100 sheets (face down) Right Side Exit Tray: 100 sheets (face down)
Cloud Supported Services	Google Cloud Print, Google Drive, Box, OneDrive for Business, SharePoint Online, Dropbox, Office 365, Gmail
Network Protocols	TCP/IP (IPv4, IPv6, IPsec), HTTP/HTTPS, IPP/IPP-SSL, FTP/FTPS, SNMPv3, SMTP/SMTP-SSL, POP3/POP3-SSL, LDAP/LDAP-SSL, 802.1x for Windows and Unix.
Network and Data Security	Includes: IP/MAC address filtering, protocol filtering, port control, user authentication (local/LDAP/Active Directory), TLS Encryption, Kerberos support
Firmware Management	Flash ROM with local (USB), network update capability and firmware update 1 to N with SRDM (Sharp Remote Device Manager)
Device Setup Service/Functions	Web-based management with user/admin level login Remote Front Panel, remote access to service logs and click counts
Accessibility Features	Free stop tilting front panel, adjustment of key touch sound and speed, concave key, document feeder free stop, job programs, remote front panel, universal grip for paper trays, and disable screen timeout
Environmental Standards	International Energy Star Program Ver. 3.0, European RoHS, Blue Angel (RAL-UZ205)
Power Source	110-127 V AC, 60 Hz, 15 A receptacle
Power Consumption	1.5 kW or less
Weight	Approx. 159 lbs.
Dimensions	Approx. 24" (w) x 26" (d) x 33" (h)
Network Printing System	
PDL	Standard PCL 6, Adobe PostScript 3
Resolution	1200 x 1200 dpi
Print Speed	50/60 pages per minute (8.5" x 11")
Print Drivers	Windows® 7, Windows 8.1, Windows 10, Windows Server® 2008, Windows Server 2012, Windows Server 2016, Windows Server 2019, Windows PPD, Mac® OS X® (including 10.9 to 10.14), all Mac PPD, UNIX®, Linux®
Mobile Printing	Android printing framework (Sharp Print Service Plugin), Sharpdesk Mobile, Google Cloud Print, Apple AirPrint
Print Features	Auto configuration, serverless print release, chapter inserts, confidential print, continuous printing, custom image registration, document control, document filing, duplex printing, electronic sorting, form overlay, hidden pattern print, image rotation, job bypass print, job retention, layout print, margin shift, multiple pamphlet, network tandem print, N-up printing, offset stacking, page interleave, pamphlet style, poster print, proof print, print and send, tab paper print, tab printing, transparency inserts, tray status, user authentication single sign-on, watermarks, zoom print
Direct Printing	File Types: TIFF, JPEG, PCL, PRN, TXT, and PNG. Optional: PDF, Compact PDF, Encrypted PDF, PS, DOCX, XLSX and PPTX. Methods: FTP, SMB, Web page, Email and USB memory. PDF file formats support the Adobe Embedded Print Engine
Resident Fonts	80 outline fonts (PCL), 139 fonts (PS)
Interface	RJ-45 Ethernet 10/100/1000 Base-T, USB 2.0, Wireless
Operating Systems and Environments	Windows 7, Windows 8, Windows 10, Windows Server 2008, Windows Server 2012, Windows Server 2016, Windows Server 2019, Chrome®, Mac OS X 10.9 to 10.14, Unix, Linux, Citrix®, and SAP device types ¹
Printing Protocols	LPR, IPP, IPPS, Raw TCP (port 9100), FTP, POP3 and HTTP
Network Scanning System	
Scan Modes	Standard: Colour, monochrome, greyscale
Max. Original Size	11" x 17"
Optical Resolution	600 dpi
Output Modes	600 dpi, 400 dpi, 300 dpi, 200 dpi, 150 dpi, 100 dpi
Image Compression	Monochrome Scanning: Uncompressed, G3 (MH), G4 (MR/MMR) Colour/Greyscale: JPEG (high, middle, low) Internet Fax mode: MH/MMR (option) ¹
Scan Destinations	Email, Desktop, FTP, Folder (SMB), USB, Internet fax (option), Super G3 fax (option)

Network Scanning System (continued)

Image Formats	Monochrome: TIFF, PDF, PDF/A-1b, PDF/A-1a, Encrypted PDF, Searchable PDF, XPS, PPTX, XLSX, DOCX, TXT, RTF Colour/Greyscale: TIFF, JPEG, PDF, PDF/A-1b, PDF/A-1a, Encrypted PDF, Compact PDF, Searchable PDF, XPS, PPTX, XLSX, DOCX, TXT, RTF Internet Fax: TIFF-FX, TIFF-F, TIFF-S ¹
One-touch Destinations	Up to 2,000 (combined scan destinations)
Group Destinations	Up to 500
Programs	48 (combined)
Max. Jobs	Up to 100
Enhanced Email Integration	Standard Gmail connector, standard Exchange connector
Scanning Protocols	HTTP/HTTPS, FTP/FTPS, SMTP/SMTP-SSL/ESMTP, SMB, POP3, LDAP, S/MIME
Software¹	Sharpdesk personal document management software, Network Scanner tool, Sharpdesk Mobile (download)
Optional Equipment	
MX60ABD	Deluxe Copier Cabinet Base (with front door)
MXDE25N	Stand/1 x 550-sheet Paper Drawer
MXDE26N	Stand/2 x 550-sheet Paper Drawers
MXDE27N	Stand/3 x 550-sheet Paper Drawers
MXDE28N	Stand/1 x 550 + 2,100-sheet Split Tandem Paper Drawers
MXLC17N	3,000-sheet Large Capacity Cassette (letter, requires MXDE25N/26N/27N/28N)
MXLT10	Long Paper Feeding Tray
MXFN27N	50-sheet Staple Inner Finisher
MXFN28	1K Stacking 50-sheet Staple Finisher
MXFN29	1K Stacking 50-sheet Staple/Saddle-Stitch Finisher
MXFN30	3K Stacking 65-sheet Staple Finisher
MXFN31	3K Stacking 65-sheet Staple/Saddle-Stitch Finisher
MXRB25N	Paper Pass Unit (required for MXFN28/29/30/31)
MXPN14B	3-Hole Punch Unit (requires MXFN27N)
MXPN15B	3-Hole Punch Unit (requires MXFN28/29)
MXPN16B	3-Hole Punch Unit (requires MXFN30/31)
MXSCX1	Staple Cartridge for MXFN27N/28
ARSC2	Saddle-stitch Staple Cartridge for MXFN29
MXSC11	Staple Cartridge for MXFN30/31
MXSC12	Saddle-stitch Staple Cartridge for MXFN31
MXTR19N	Right Side Exit Tray
MXTR20	Job Separator Tray
MXTU16	Centre Exit Tray
MXUT10	Utility Table
MXFX15	Fax Expansion Kit
MXFWX1L	Internet Fax Kit
MXPF10	Bar Code Font Kit
ARSU1	Stamp Unit (requires ARSV1 Stamp Cartridge)
ARSV1	Stamp Cartridge
MXAMX1L	Application Integration Module
MXFR64U	Data Security Kit
DVENDFSV	Generic Vendor Interface Kit
Supplies	
MX561NT	Toner Cartridge
MX561NV	Developer
MX560DR	Drum
MX609HB	Toner Collection Container

¹ Some features require optional equipment. See your local dealer.

² May vary depending on product configuration, machine settings and operating and/or environmental conditions.



Design and specifications subject to change without notice. Sharp, Sharp OSA, Sharpdesk, YourSharp, and all related trademarks are trademarks or registered trademarks of Sharp Corporation and/or its affiliated companies. Microsoft, Office 365, Active Directory, Windows, Windows Server, Excel, PowerPoint, OneDrive, and SharePoint are trademarks or registered trademarks of Microsoft Corporation. Android, Chrome, Gmail, Google Drive, Google Cloud Print, and Chromebook are trademarks or registered trademarks of Google LLC. Adobe, the Adobe logo, PostScript, and PostScript 3 are either registered trademarks or trademarks of Adobe in the United States and/or other countries. Qualcomm DirectOffice is a product of Qualcomm Technologies, Inc. and/or its subsidiaries. Qualcomm is a trademark of Qualcomm Incorporated, registered in the United States and other countries. DirectOffice is a trademark of CSR Imaging US, LP, registered in the United States and other countries, used with permission. All other trademarks are the property of their respective owners. ©2019 Sharp Electronics of Canada Ltd.

335 Britannia Road East, Mississauga, ON L4Z 1W9
150 York Street, Suite 1702, Toronto, ON M5H 3S5
www.sharp.ca

SHARP
Be Original.